

GPS/GLONASS Passive Antenna

VTPGPGL-7

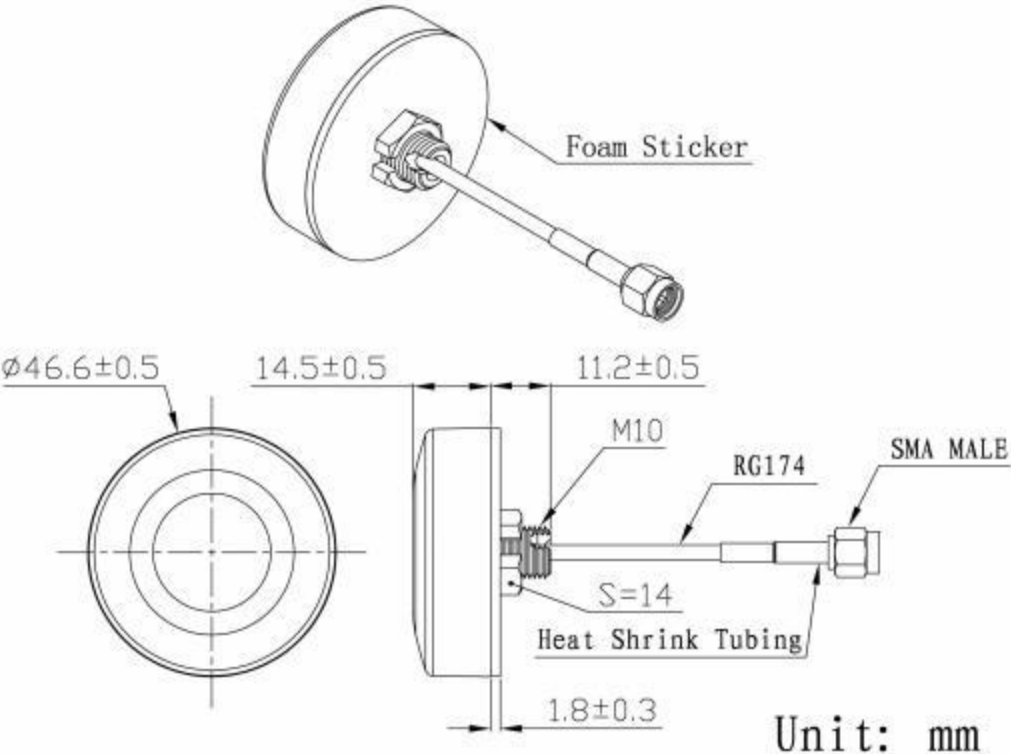

DIMENSIONS



SPECIFICATIONS

Item		Specifications
Antenna	Center Frequency	1575 - 1602±3MHz
	Band Width	CF±5MHz
	Polarization	RHCP
	Gain	2dBic (Zenith)
	V.S.W.R	<1.5
	Impedance	50 Ω
	Axial Ratio	3dB (max)
	Dimension	25*25*4mm
Mechanical	Cable	RG174
	Connector	FME
	Radome Material	ABS
	Mounting Method	Screw
Environmental	Operating Temperature	-40C~+85C
	Relative Humidity	Up to 95%
	Ingress Protection	IP65~IP67 (exclude cable outlet)
	Vibration	10 to 55Hz with 1.5mm amplitude 2hours
	Environmentally Friendly	ROHS Compliant