

Iridium Antenna VTIA-3

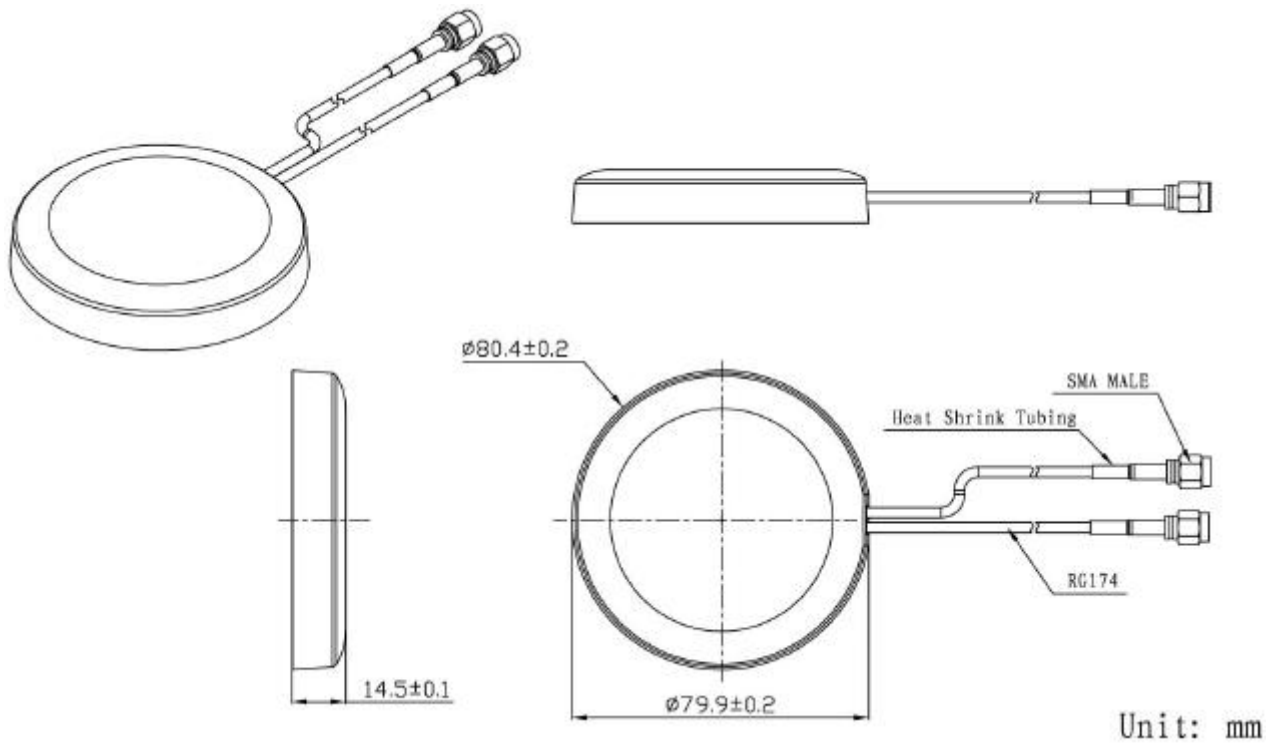

DIMENSIONS



SPECIFICATIONS

Item		Specifications	
Receiver Antenna	Dielectric Antenna	Frequency Range	1616~1626.5MHz
		Band Width	10.5MHz
		Polarization	RHCP
		Gain	2dBic (Zenith)
		V.S.W.R	<1.5
		Impedance	50Ω
		Axial Ratio	3dB (max)
	LNA	Gain	26±1dB
		Noise Figure	<1.3
		V.S.W.R	<2.0
		Supply Voltage	3~5V DC
	Current Consumption	18~20mA	
Transmitter Antenna (Dielectric Antenna)		Frequency Range	1621.35~1626.5MHz
		Band Width	5.15MHz
		Polarization	RHCP
		Gain	2dBic (Zenith)
		V.S.W.R	<1.5
		Impedance	50Ω
		Axial Ratio	3dB (max)
Mechanical		Cable	RG174 or others
		Connector	SMA/MCX/FAKRA or others
		Radome Material	ABS
		Mounting Method	Magnet/Adhesive
Environmental		Operating Temperature	-40°C~+85°C
		Relative Humidity	Up to 95%
		Ingress Protection	IP65~IP66
		Vibration	10 to 55Hz with 1.5mm amplitude 2hours
		Environmentally Friendly	ROHS Compliant

Radiation Pattern

Transmitter Antenna

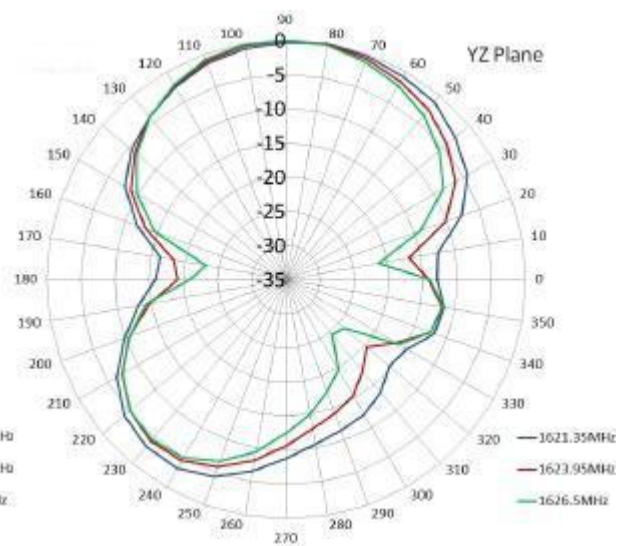
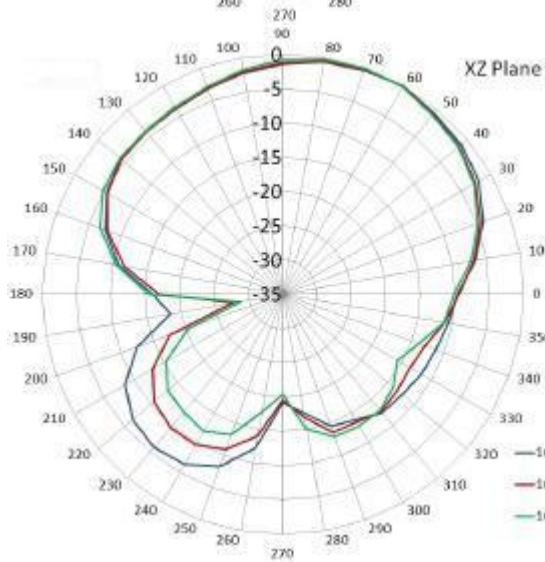
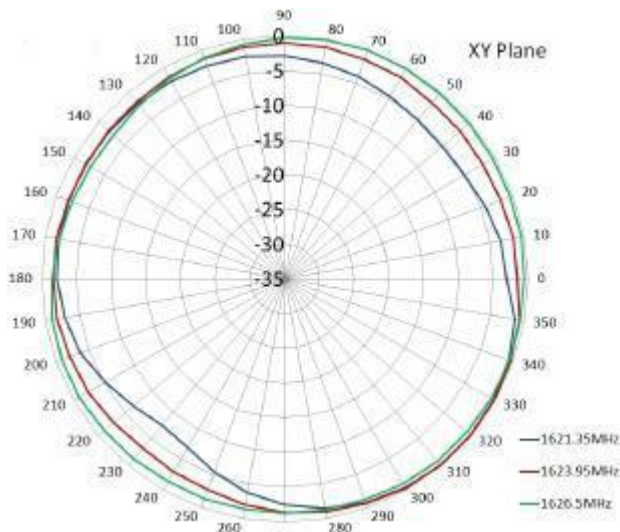

Receiver Antenna

