

Iridium Antenna VTIA-6

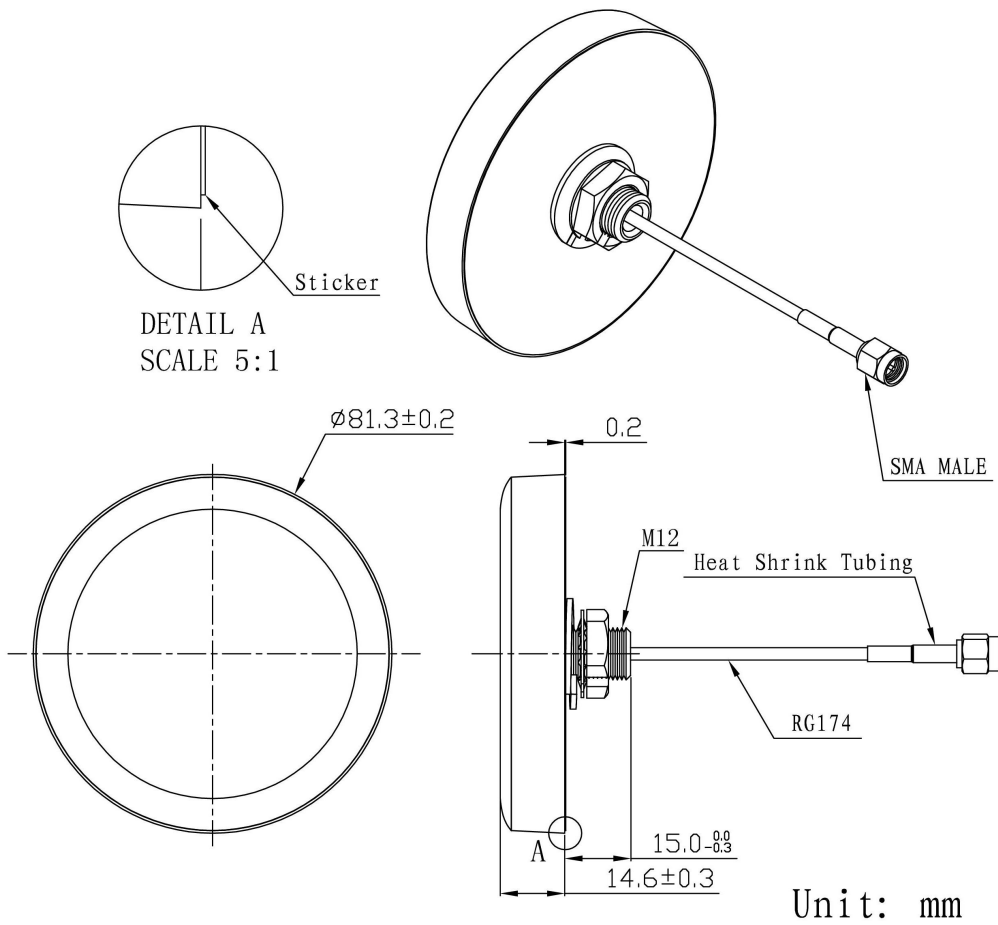

DIMENSIONS



SPECIFICATIONS

Item		Specifications	
Receiver Antenna	Dielectric Antenna	Frequency Range	1616~1626.5MHz
		Band Width	10.5MHz
		Polarization	RHCP
		Gain	2dBic (Zenith)
		V.S.W.R	<1.5
		Impedance	50Ω
		Axial Ratio	3dB (max)
	LNA	Gain	26±1dB
		Noise Figure	<1.3
		V.S.W.R	<2.0
Supply Voltage		3~5V DC	
Current Consumption		18~20mA	
Transmitter Antenna (Dielectric Antenna)	Frequency Range	1621.35~1626.5MHz	
	Band Width	5.15MHz	
	Polarization	RHCP	
	Gain	2dBic (Zenith)	
	V.S.W.R	<1.5	
	Impedance	50Ω	
	Axial Ratio	3dB (max)	
Mechanical	Cable	RG174 or others	
	Connector	SMA/MCX/FAKRA or others	
	Radome Material	ABS	
	Mounting Method	Screw	
Environmental	Operating Temperature	-40°C~+85°C	
	Relative Humidity	Up to 95%	
	Ingress Protection	IP65~IP67	
	Vibration	10 to 55Hz with 1.5mm amplitude 2hours	
	Environmentally Friendly	ROHS Compliant	

Radiation Pattern

Transmitter Antenna

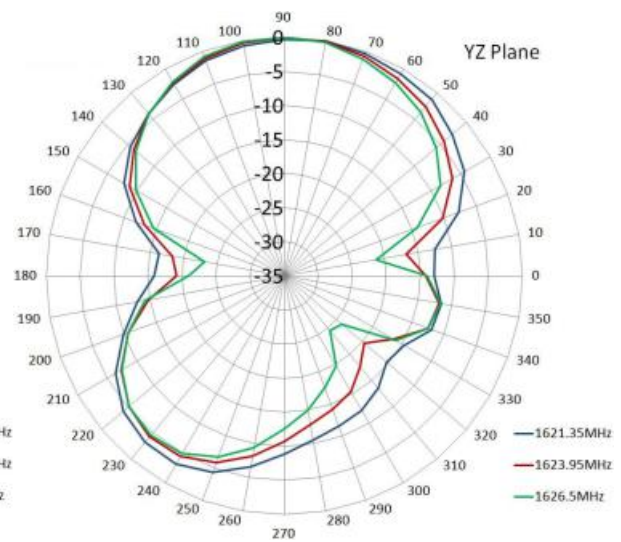
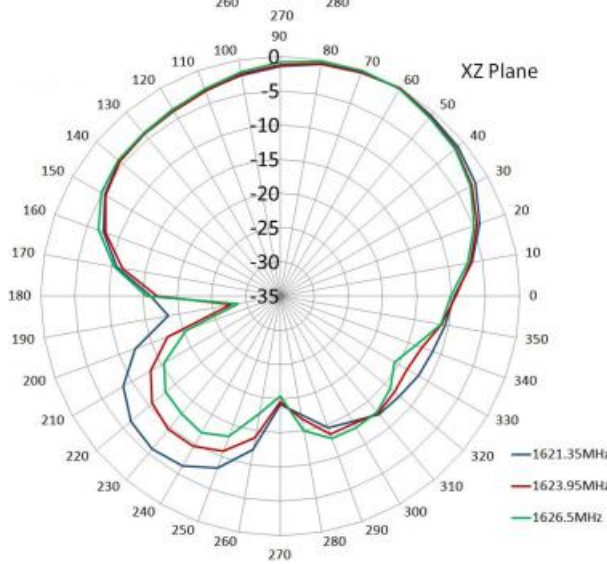
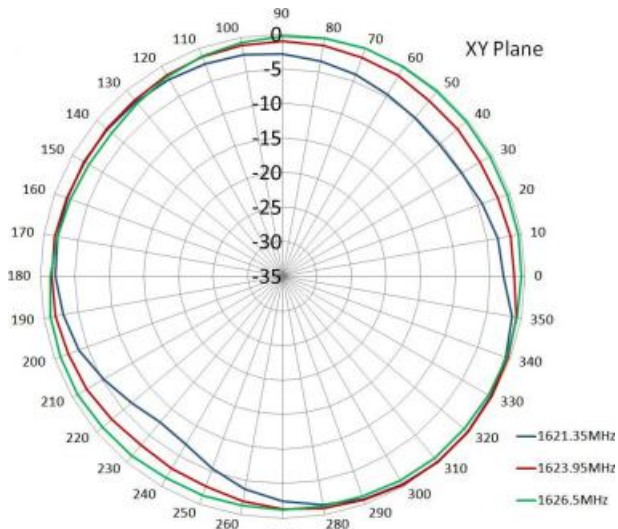

V.TORCH

Receiver Antenna

