

GSM Internal Antenna VTGSMIA-5

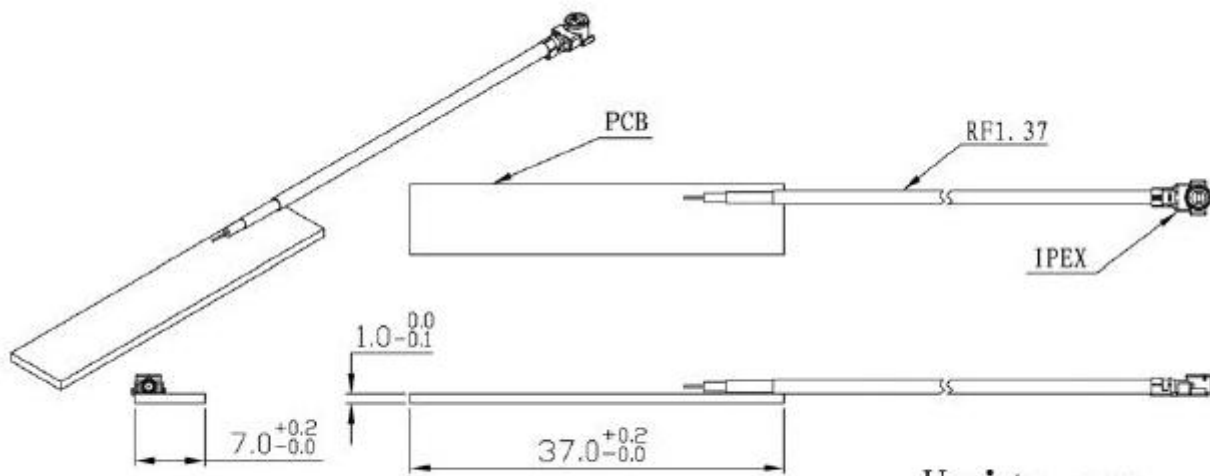

DIMENSIONS



SPECIFICATIONS

Item	Specifications	
Antenna	Frequency Range	824~960 1710~2170MHz
	Polarization	Linear
	Gain	2dBi
	V.S.W.R	<2.0
	Impedance	50 Ω
	PCB Dimension	37*7*1mm
Mechanical	Cable	RF1.13/RF1.37 or others
	Connector	IPEX
	Mounting Method	Adhesive
Environmental	Operating Temperature	-40°C~+85°C
	Vibration	10 to 55Hz with 1.5mm amplitude 2hours
	Environmentally Friendly	ROHS Compliant

Radiation Pattern

