

SAW FILTER Part Number: VTFGP001

Features

SAW filter for GPS.

- 1 High stability and reliability with good performance and no adjustment.
- 2 Narrow and sharp pass band characteristics. RoHS compatible.
- 3 Low insertion loss and deep stop band attenuation for interference.
- 4 Low – loss SAW filter for GPS.
- 5 Package size 1.4*1.1

Package Dimensions

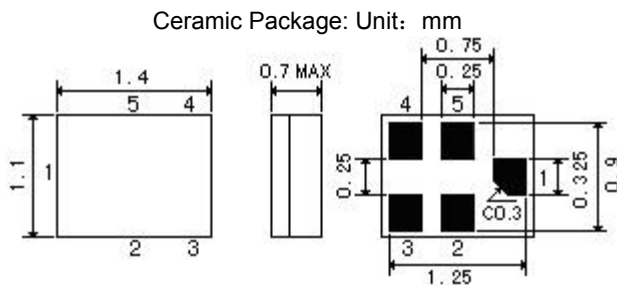

Pin Configuration

1	Input
4	Output
2,3,5	Ground

Marking

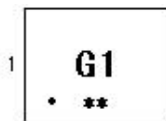

Top View, Laser Marking			
"G1":	Part number	"1":	Terminal 1
"*":	Lot number (The code shown below varies in a 4-year cycle)		

Code	1	2	3	4	5	6	7	8	9	10	11	12
2015	a	b	c	d	e	f	g	h	i	j	k	m
2016	n	p	q	r	s	t	u	v	w	x	y	z
2017	A	B	C	D	E	F	G	H	J	K	L	M
2018	N	P	Q	R	S	T	U	V	W	X	Y	Z

Maximum Ratings

Rating		Value	Unit
DC Voltage (between any Terminals)	V_{DC}	10	V
RF Power (in BW)	P	10	dBm
Operating Temperature Range	T_A	-40 ~ +85	°C
Storage Temperature Range	T_{stg}	-40 ~ +85	°C

Electrical Characteristics:

Item		Minimum	Typical	Maximum	Unit
Center Frequency	fC	-	1575.42	-	MHz
Maximum Insertion Loss in 1574.42–1576.42MHz	IL	-	1.2	1.5	dB
Amplitude Variation in 1574.42–1576.42MHz			0.1	0.5	dB
Absolute Attenuation	α				
0.30 ... 1450.0MHz		35	39	-	dB
1450.0 ... 1525.0 MHz		38	45	-	dB
1620.0 ... 1640.0 MHz		45	48	-	dB
1640.0 ... 1805.0MHz		38	40		dB
1805.0 ... 1910.0 MHz		38	40	--	dB
1910.0 ... 2000.0 MHz		38	43	--	dB
2000.0 ... 4000.0 MHz		30	45	--	dB
4000.0 ... 6000.0 MHz		20	22	--	dB
VSWR in 1574.42–1576.42MHz		-	1.15	1.5	

 **RoHS Compliant**

 **Electrostatic Sensitive Device**

Typical Frequency Response

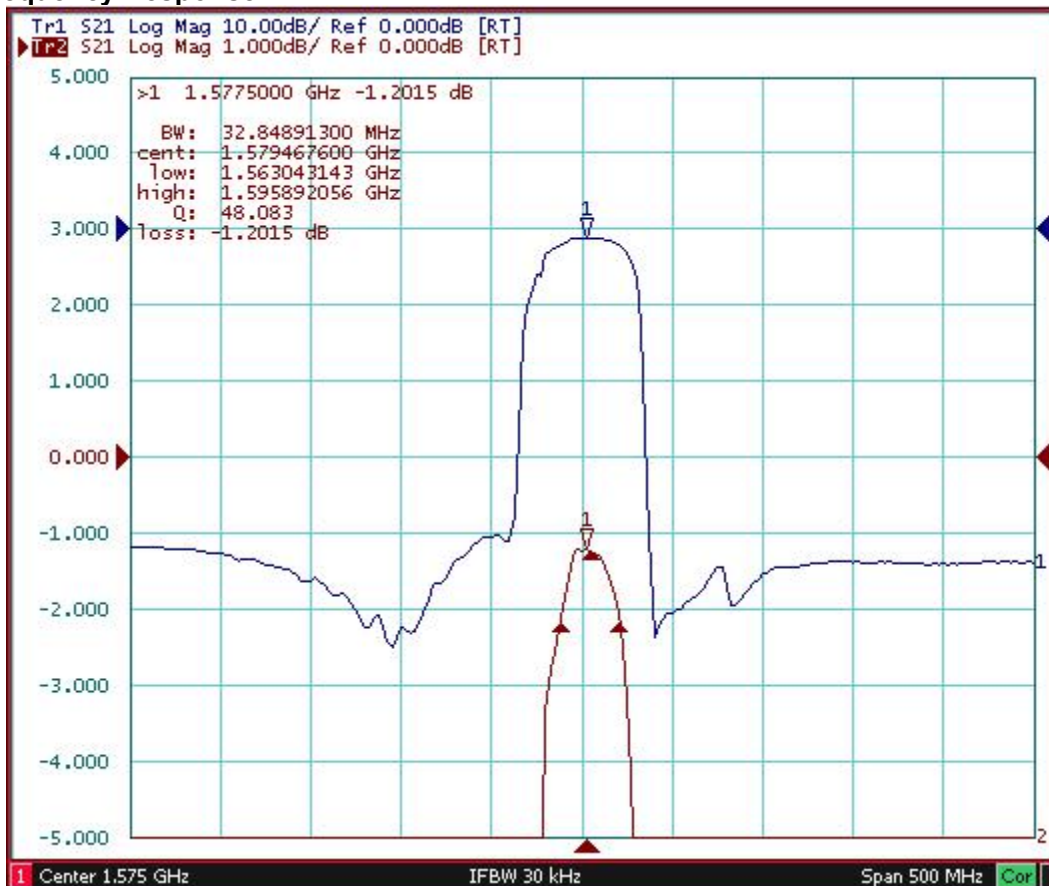

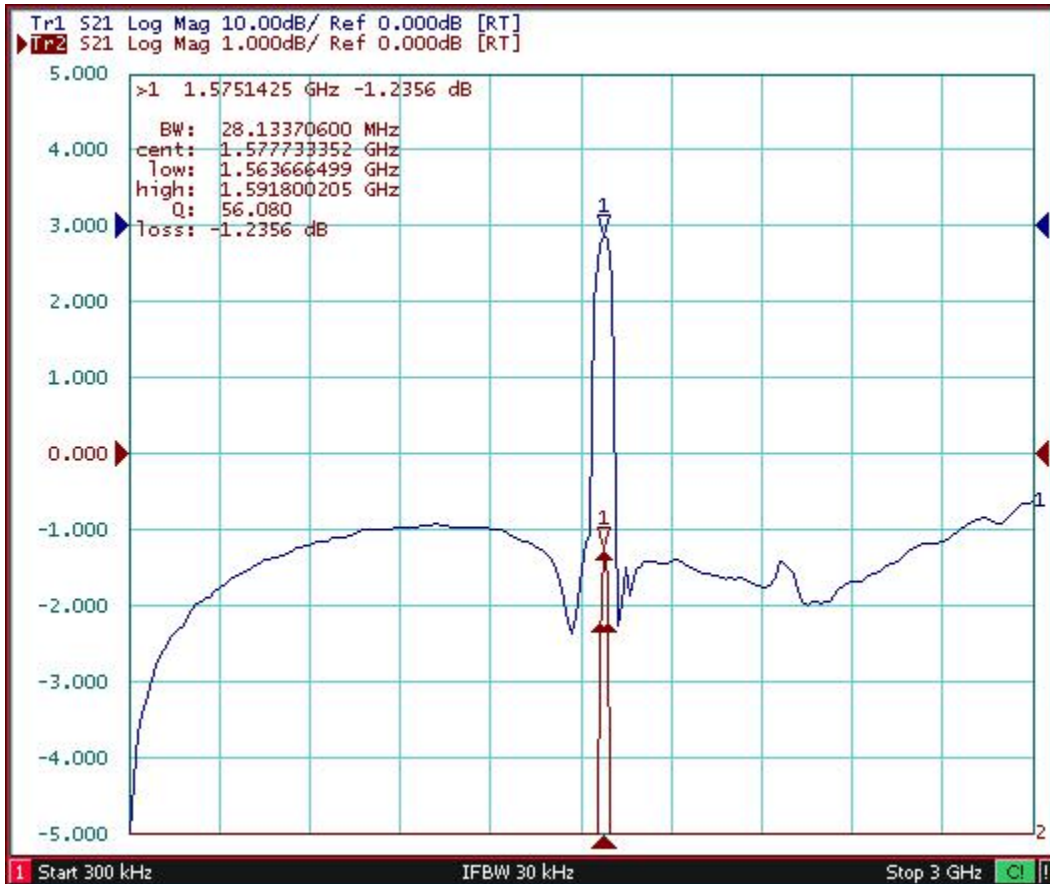

Stability Characteristics

	Test item	Condition of test
1	Mechanical shock	(a) Drops: 3 times on concrete floor (b) Height: 1.0 m
2	Vibration resistance	(a) Frequency of vibration: 10~55Hz (c) Directions: X,Y and Z (b) Amplitude: 1.5 mm (d) Duration: 2 hours
3	Moisture resistance	(a) Condition: 40°C ± 2°C , 93+2 -3% RH. (b) Duration: 96 hours (c) Wait 4 hours before measurement
4	Climatic sequence	(a) +70°C for 16 hours (c) -25°C for 2 hours (e) Wait 4 hours before measurement (b) +55°C for 24 hours, 90~95% R.H. (d) +40°C for 24 hours, 90~95% R.H.
5	High temperature exposure	(a) Temperature: 85°C (c) Wait 4 hours before measurement (b) Duration: 250 hours
6	Temperature cycling	(a) +85°C for 30 minutes ⇒ -40°C for 30 minutes repeated 120 times (b) Wait 4 hours before measurement

V.TORCH

Packing Information

Carrier Tape

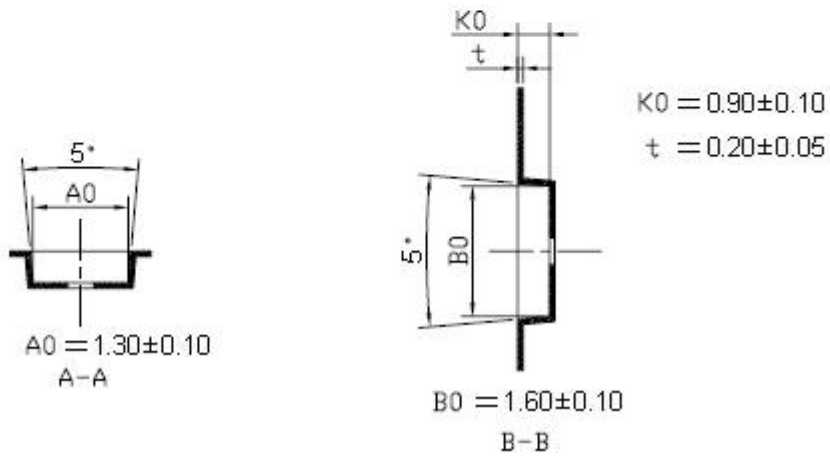
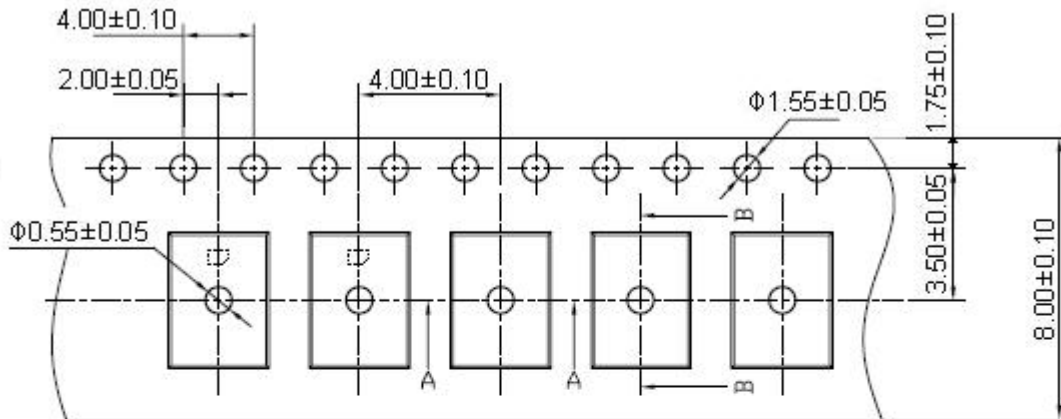

Reel Dimensions

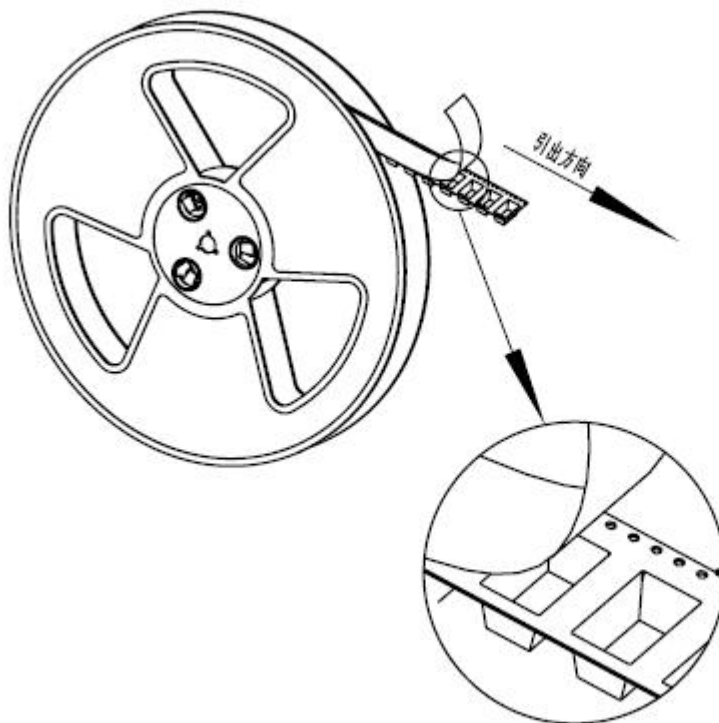

Material	PS
Unit	mm
Tolerance	± 0.20 mm
Quantity	3000/reel

Outer Packing

Type	Quantity	Dimension	Description	Weight
Carton Box I	10000	190×190×95	anti-static plastic bag & carton box 1 reel / bag 5 bags / box (10000 pcs) 10 bags / box (20000 pcs)	0.85
Carton Box II	20000	190×190×190		1.80

Unit: mm

Unit: kg

Requirements: The SAW filter shall remain within the electrical specifications after tests.

Remarks

- SAW devices should not be used in any type of fluid such as water, oil, organic solvent, etc.
- Be certain not to apply voltage exceeding the rated voltage of components.
- Do not operate outside the recommended operating temperature range of components.
- Sudden change of temperature shall be avoided, deterioration of the characteristics can occur.
- Be careful of soldering temperature and duration of components when soldering.
- Do not place soldering iron on the body of components.
- Be careful not to subject the terminals or leads of components to excessive force.
- SAW devices are electrostatic sensitive. Please avoid static voltage during operation and storage.
- Ultrasonic cleaning shall be avoided. Ultrasonic vibration may cause destruction of components.

Test Circuit

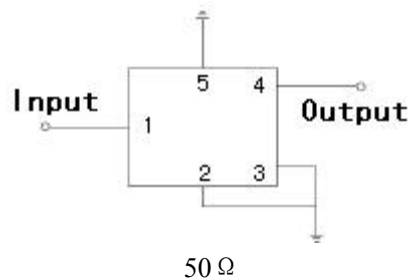

Recommended Soldering Profile

V.TORCH

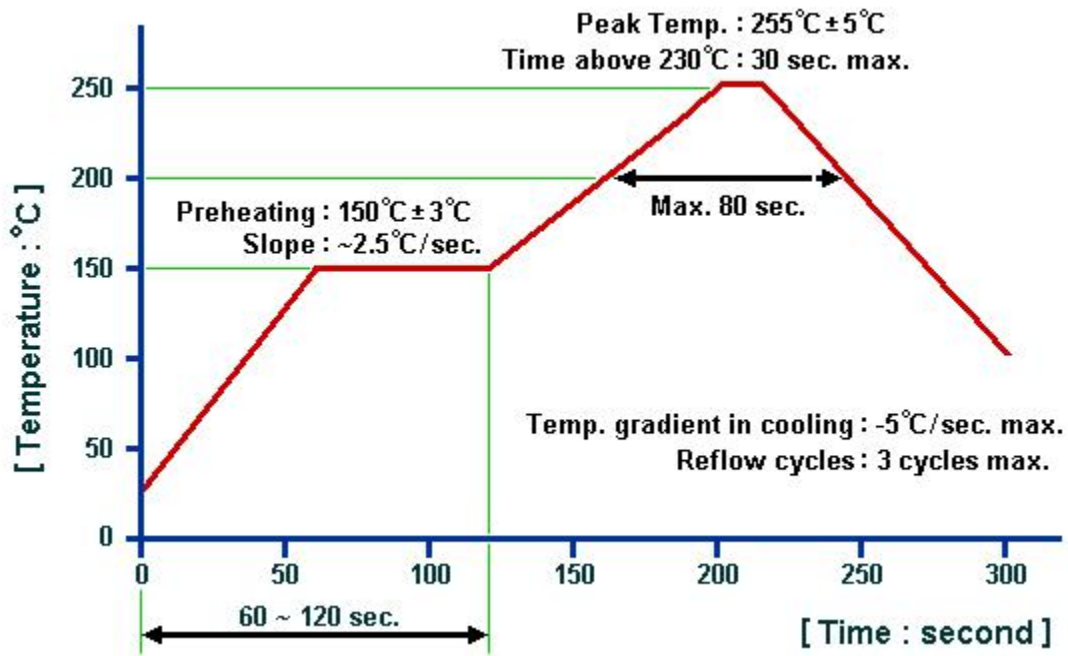

© V.TORCH 2015. All Rights Reserved.

1. The specifications of this device are subject to change or obsolescence without notice.
2. Typically, equipment utilizing this device requires emissions testing and government approval, which is the responsibility of the equipment manufacturer.
3. Our liability is only assumed for the Surface Acoustic Wave (SAW) component(s) per se, not for applications, processes and circuits implemented within components or assemblies.
4. For questions on technology, prices and delivery, please contact our sales offices or e-mail info@v-torch.com.