

GSM Antenna

Part Number: VTGSMA-76

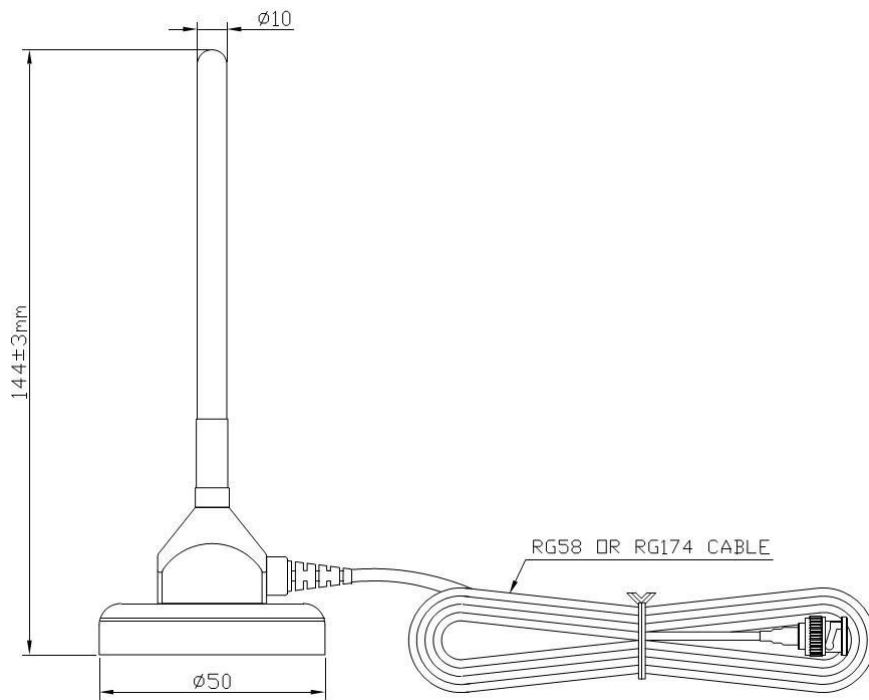

1.Dimension (Unit: mm)



2. Electrical Characteristics

Form1

No.	Item	Specifications
1	Frequency (MHz)	824-2200 MHz
2	V.S.W.R (in BW)	1:1.8
3	Gain (Zenith)	3dbi
4	Polarization	Vertical
5	Impedance	50 Ω
6	Max Power	50W
7	Radiation	All Directional
8	Lightning Protection:	DC Grounding

3.Mechanical

Form2

No.	Item	Specification
1	Cable	RG58 OR RG174 1.5M
2	Connector	SMA OR BNC
3	Plastic Housing	Black
4	Height	144mm
5	Max diameter	50mm
6	Min diameter	10mm

V.TORCH

CHI A/R SWR MKR 1: 1.3860 U
 REF 1.000 U 1.000U/ 824 000 000.HZ

