

GPS Ceramic Patch Antennas

Part Number:VTCA1575R1220A

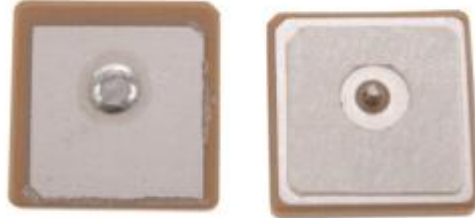

1.Mechanical Drawing

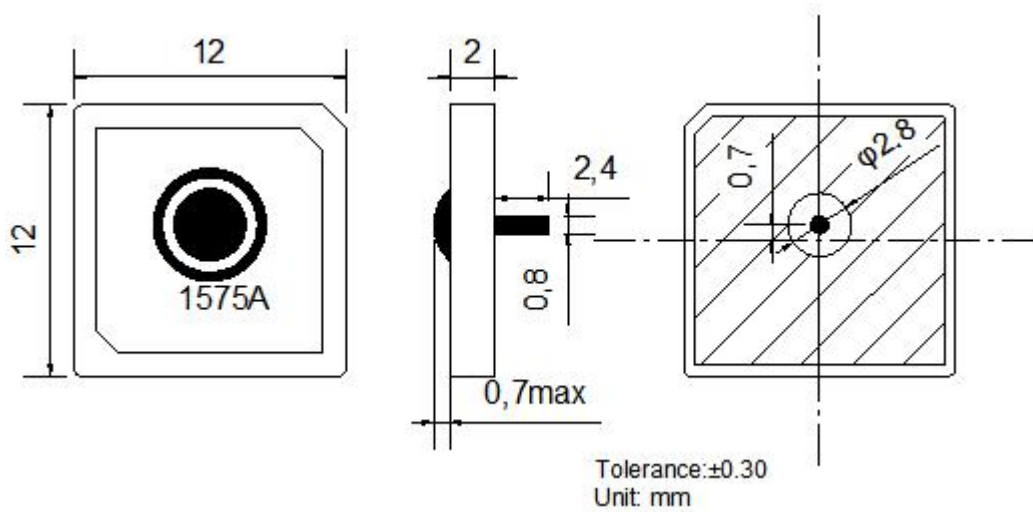

2.Electrical Characteristics

Fom1

No.	Item	Specifications
1	Frequency (MHz)	1575.42±3 MHz
2	Return Loss @ F0	≥15 dB
3	Gain@ Zenith	-5.0 dBi typ.
4	Ground plane	12 x 12 mm
5	Polarization	RHCP
6	Impedance	50 Ω

V.TORCH

3.Environmental Characteristics

Fom2

No.	Item	Specification
1	Environmental Operating Temperature	-40 ~ +85°C
2	Frequecy Temperature Coefficient	±20 ppm/°C
3	Environmentally Friendly	ROHS Compliant

4.Test Fixture

