

GPS+GLONASS Active Antenna VTGPGL-2

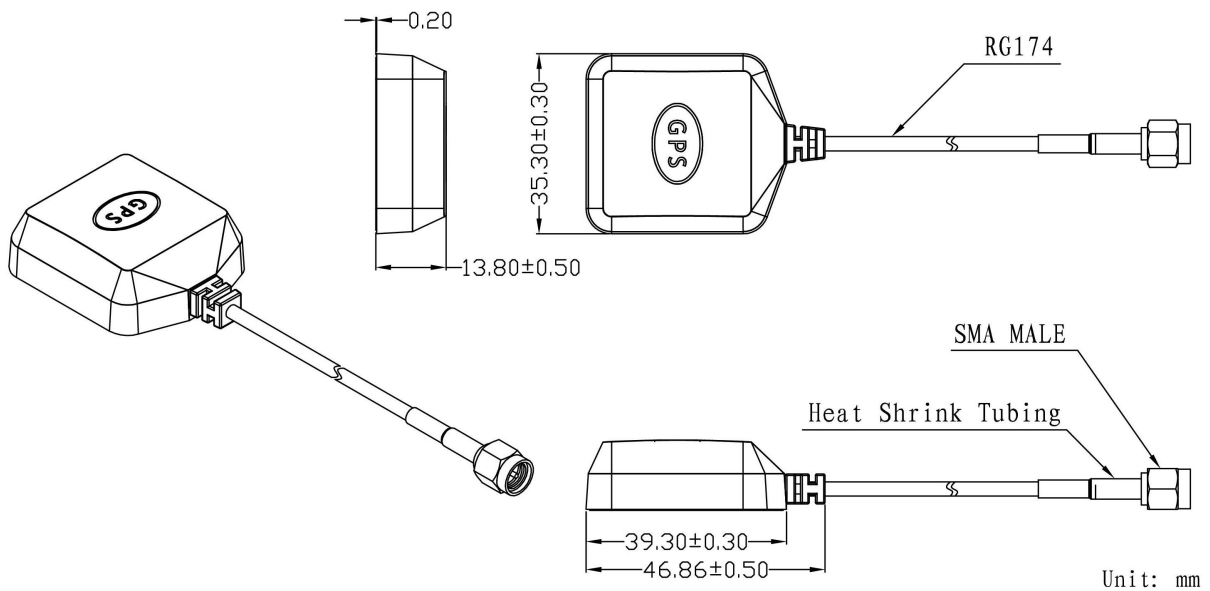

DIMENSIONS



SPECIFICATIONS

Item		Specifications
Antenna	Center Frequency	1575.42 ± 3MHz, 1602 ± 5MHz
	Band Width	CF ± 5MHz
	Polarization	RHCP
	Gain	2dBic (Zenith)
	V.S.W.R	<1.5
	Impedance	50 Ω
	Axial Ratio	3dB (max)
	Dimension	25*25*4mm
LNA	Gain	28 ± 2dB
	Noise Figure	<1.5
	Filter Insertion Loss	<3dB
	Ex-band Attenuation	12dB@CF+50MHz/16dB@CF-50MHz
	Supply Voltage	2.2~5V DC
	Current Consumption	5~15mA
	V.S.W.R	<2.0
Mechanical	Cable	RG174
	Connector	SMA/MCX/FAKRA or others
	Radome Material	ABS
	Mounting Method	Magnet/Adhesive
Environmental	Operating Temperature	-40°C~+85°C
	Relative Humidity	Up to 95%
	Ingress Protection	IP66
	Vibration	10 to 55Hz with 1.5mm amplitude 2hours
	Environmentally Friendly	ROHS Compliant

Radiation Pattern

