

# GSM Internal Antenna VTGSMIA-1

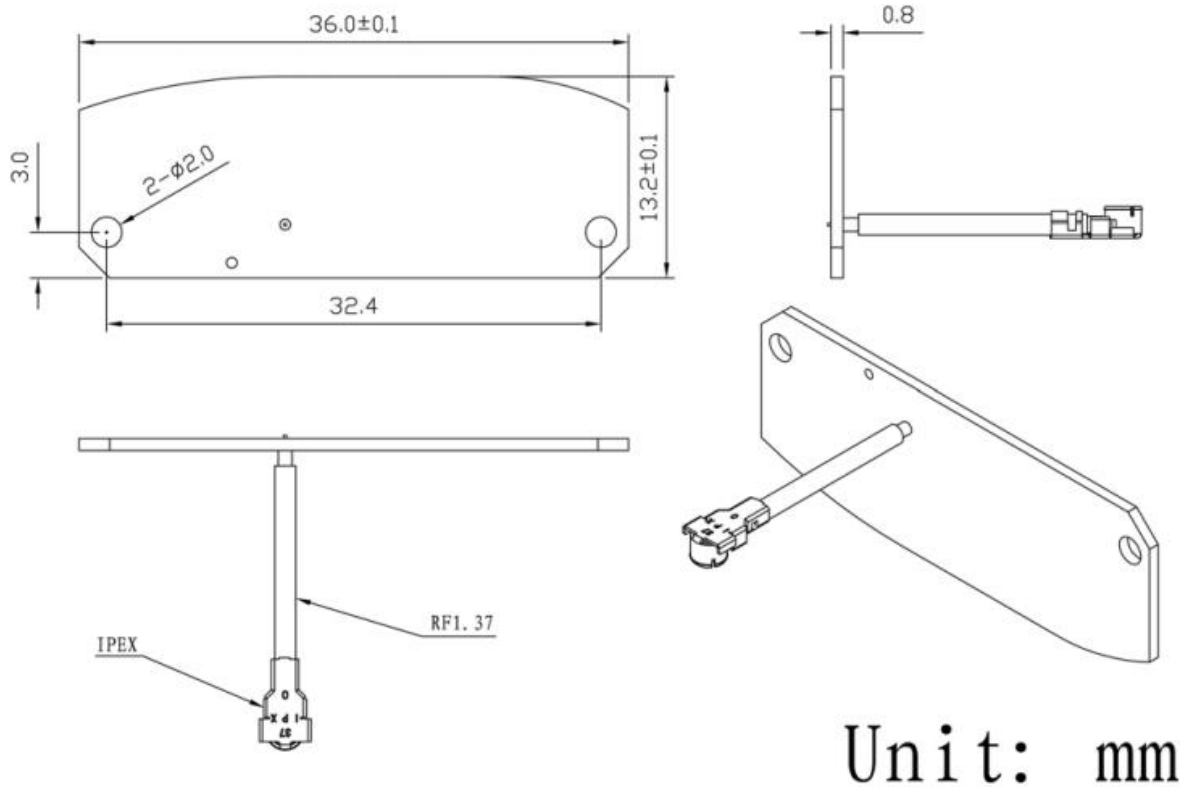

## DIMENSIONS



## SPECIFICATIONS

Item	Specifications	
Antenna	Frequency Range	824~960/1710~1990MHz
	Polarization	Linear
	Gain	2dBi (Zenith)
	V.S.W.R (min)	<3.0
	Impedance	50 Ω
	PCB Dimension	36*13.2*0.8mm
Mechanical	Cable	RF1.37 or others
	Connector	IPEX or others
	Mounting Method	Adhesive
Environmental	Operating Temperature	-40°C~+85°C
	Relative Humidity	Up to 95%
	Vibration	10 to 55Hz with 1.5mm amplitude 2hours
	Environmentally Friendly	ROHS Compliant

## Radiation Pattern

