

## GPS+GSM +3G Combination Antenna

Part Number: **VTGPSM-2**

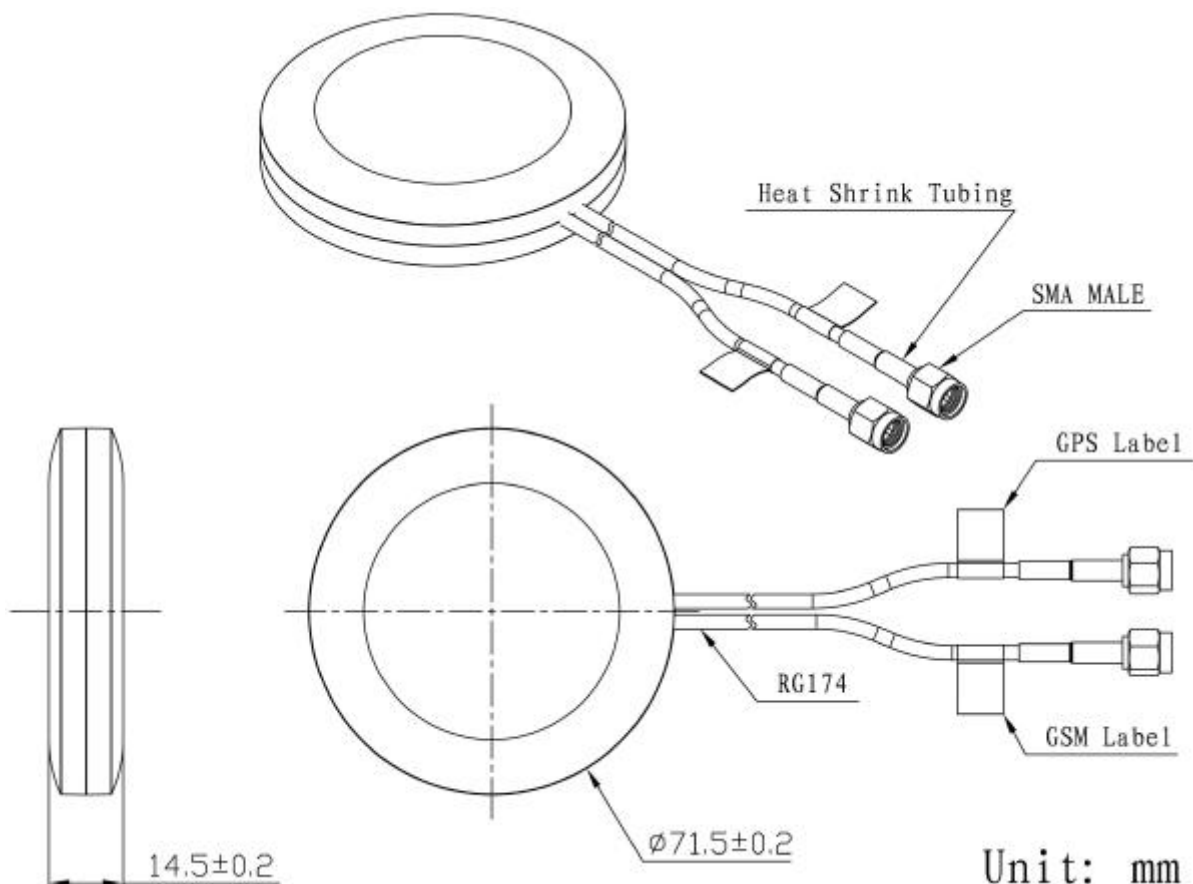

### DIMENSIONS



Unit: mm

## SPECIFICATIONS

Item		Specifications	
GPS Antenna	Dielectric Antenna	Center Frequency	1575.42±1MHz
		Band Width	CF±5MHz
		Polarization	RHCP
		Gain	5dBic (Zenith)
		V.S.W.R	<1.5
		Impedance	50Ω
		Axial Ratio	3dB (max)
	LNA	Gain	28±2dBi
		Noise Figure	<1.5
		Ex-band Attenuation	12dB@CF+50MHz/16dB@CF-50MHz
		V.S.W.R	<2.0
		Supply Voltage	2.2~5V DC
		Current Consumption	5~15mA
		GSM /3G Antenna	Frequency Range
V.S.W.R (min)	<2.5		
Polarization	Linear		
Gain	2dBi		
Impedance	50Ω		
Mechanical	Cable	RG174	
	Connector	SMA/MCX/FAKRA or others	
	Radome Material	ABS	
	Mounting Method	Magnet/Adhesive/Screw	
Environmental	Operating	-40℃~+85℃	
	Relative Humidity	Up to 95%	
	Ingress Protection	IP66	
	Vibration	10 to 55Hz with 1.5mm amplitude 2hours	
	Environmentally	ROHS Compliant	

## Radiation Pattern

### GPS Antenna

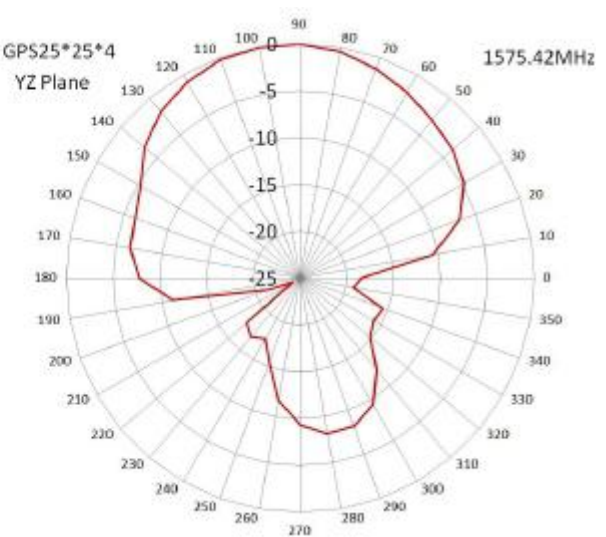
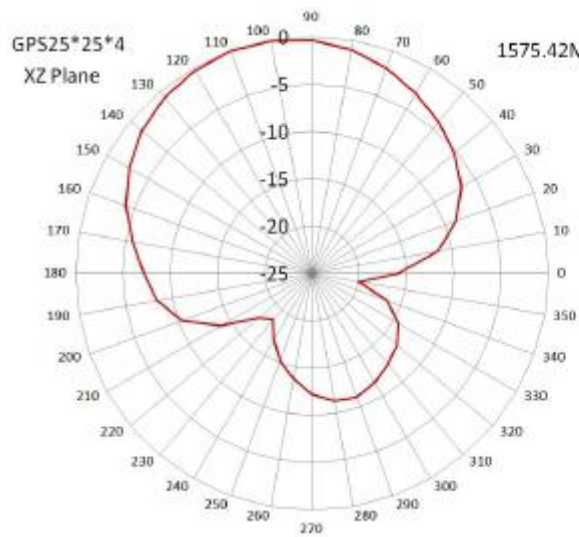
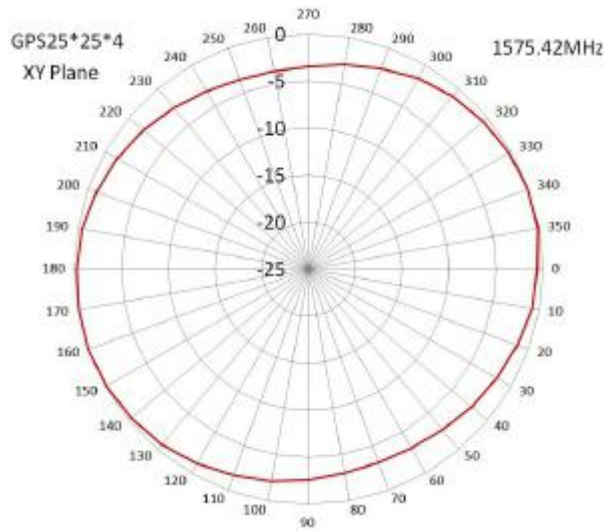

### GSM/3G Antenna

