

## PIEZO ULT RASONIC SENSOR

Part Number: VT-US175D1901

### Applications

- 1.1)Level measurement
- 1.2)Automation control
- 1.3)Proximity
- 1.4)Obstacle avoidance
- 1.5)Robotics

### Feature

- 2.1)Rugged sealed construction.
- 2.2)Cylindrical design allows for installation in various applications.
- 2.3)Short-range measurement capabilities.



1.Dimension (Unit: mm)

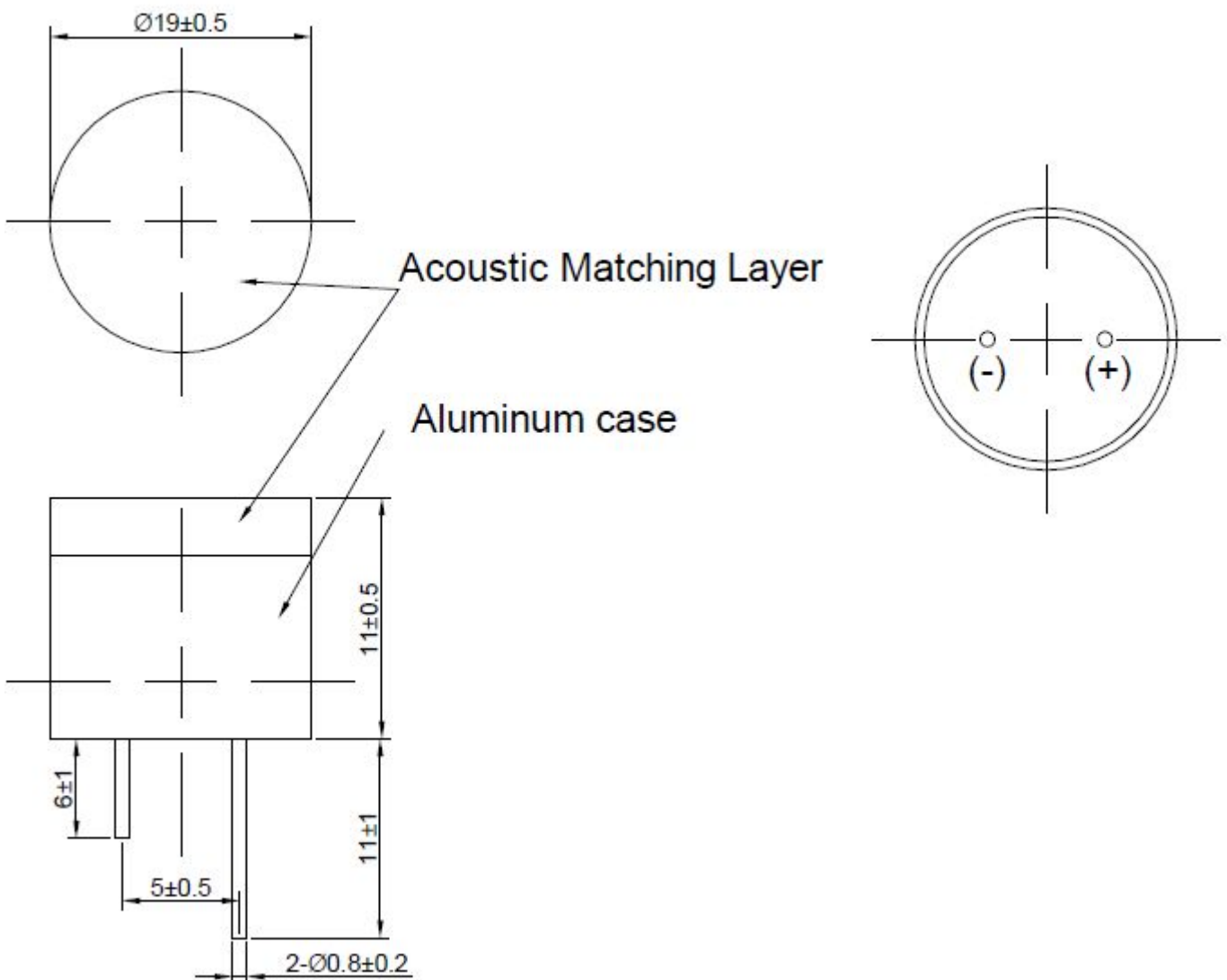

2.Electrical Characteristics

No.	Item	Unit	Specifications
1	Construction		Water Proof
2	Using Method		Dual Use
3	Center Frequency	Khz	175±10khz
4	Receive Sensitivity Echo	mV	≥1.0(driver signal:200Vp-p,175KHz,at 20cm)
5	Capacitance	pF	900pF±25% at 1KHz
6	Max. Input Voltage	Vp-p	500Vp-p
7	Directivity(-3dB)	°	7±2
8	Distance of Detection	M	0.1~2M
9	Protection class		IP65
10	Material		Aluminum
11	Operating Tem.Range	°C	-20 to +80°C
12	Storage Tem.Range	°C	-35 to +85°C

3.Directivity

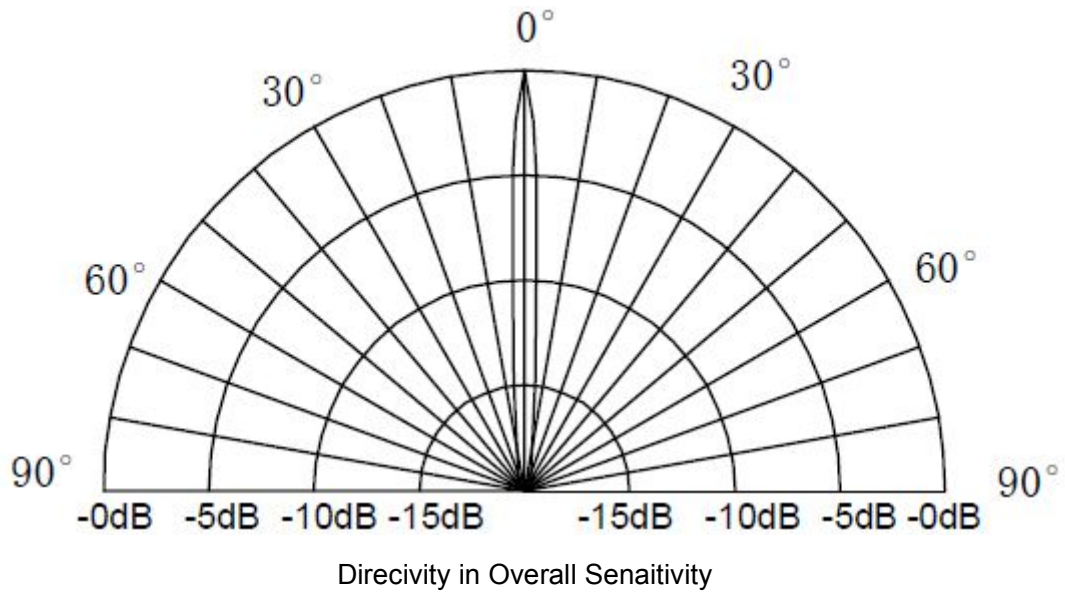

4. Test circuit

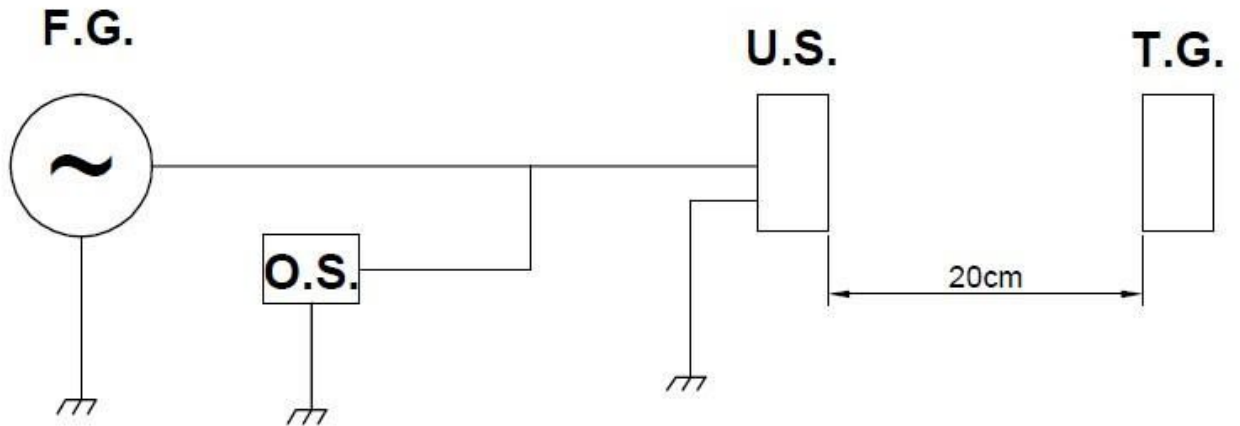

F.G.:Function Generator  
U.S :Ultrasonic Sensor  
T.G:Target  
O.S.:Oscoilloscope

5.Echo sensitivity/Ringing

Driver signal:200Vp-p,20cm

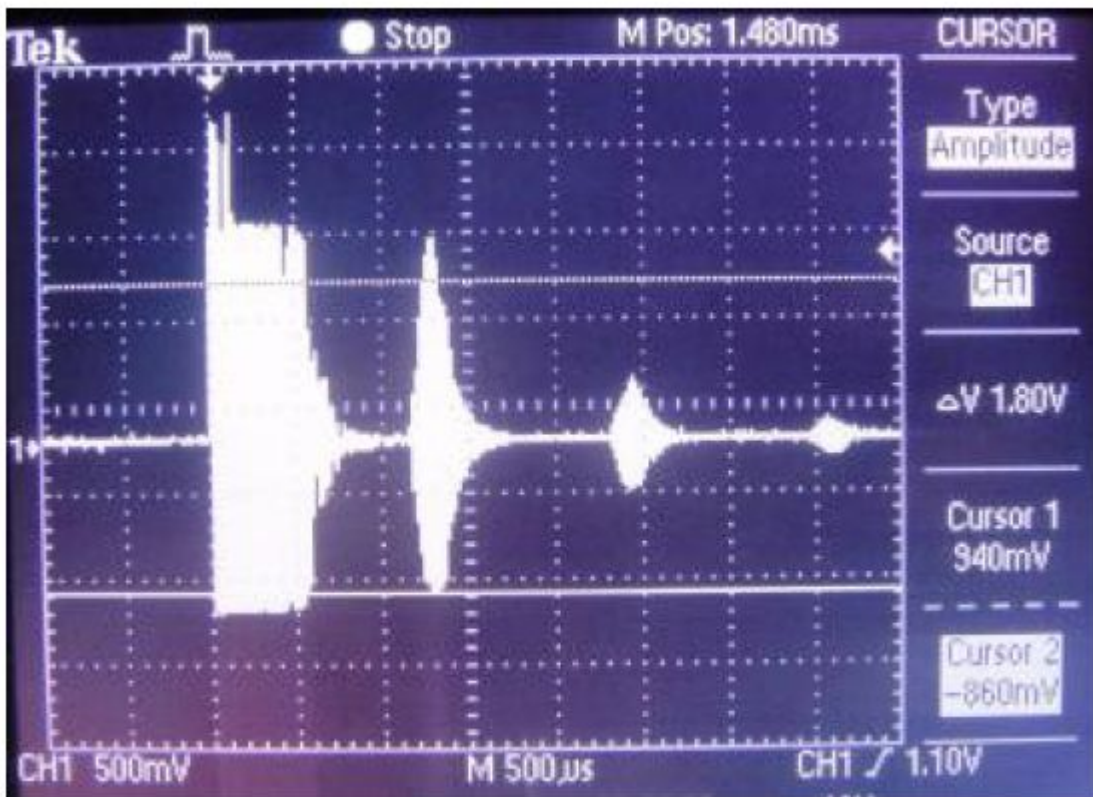

## 6. Notice

### 6.1 Export Control <For customers outside The People's Republic of China>

No BeStar products should be used or sold, through any channels, for use in the design, development, production, utilization, maintenance or operation of, or otherwise contribution to

(1) any weapons (Weapons of Mass Destruction [nuclear, chemical or biological weapons or missiles] or conventional weapons) or

(2) goods or systems specially designed or intended for military end-use or utilization by military end-users.

6.2 Please contact our sales representatives or product engineers before using the products in the specification or catalogue for the applications listed below, which require especially high reliability for the prevention of defects which might directly damage a third party's life, body or property, or when one of our products is intended for use in applications other than those specified in this specification.

a) Aircraft equipment or Aerospace equipment

b) Undersea equipment and Power plant equipment

c) Medical equipment and Transportation equipment (vehicles, trains, ships, etc.)

d) Traffic signal equipment i Disaster prevention / crime prevention equipment

e) Data-processing equipment including Application of similar complexity and/or reliability requirements to the applications listed above

6.3 Product specifications and catalogues are subject to change and our products in them may be discontinued without advance notice.

Please check with our sales representatives or product engineers before ordering. If there are any questions, please contact our sales representatives or product engineers.

6.4 Please read rating and CAUTION (for storage, operating, rating, soldering, mounting and handling) in this specifications in order to prevent smoking and/or burning, etc.

6.5 Please note that unless otherwise specified, we shall assume no responsibility whatsoever for any conflict or dispute that may occur in connection with the effect of our and/or a third party's intellectual property rights and other related rights in consideration of your use of our products and/or information described or contained in our specifications and catalogues. In this connection, no representation shall be made to the effect that any third parties are authorized to use the rights mentioned above under licenses without our consent.

6.6 No ozone depleting substances (ODS) under the Montreal Protocol are used in our manufacturing process.